

TECHNICAL SPECIFICATIONS FOR CONTINUOUS AMBIENT AIR QUALITY MONITORING (CAAQM) STATION (REAL TIME)

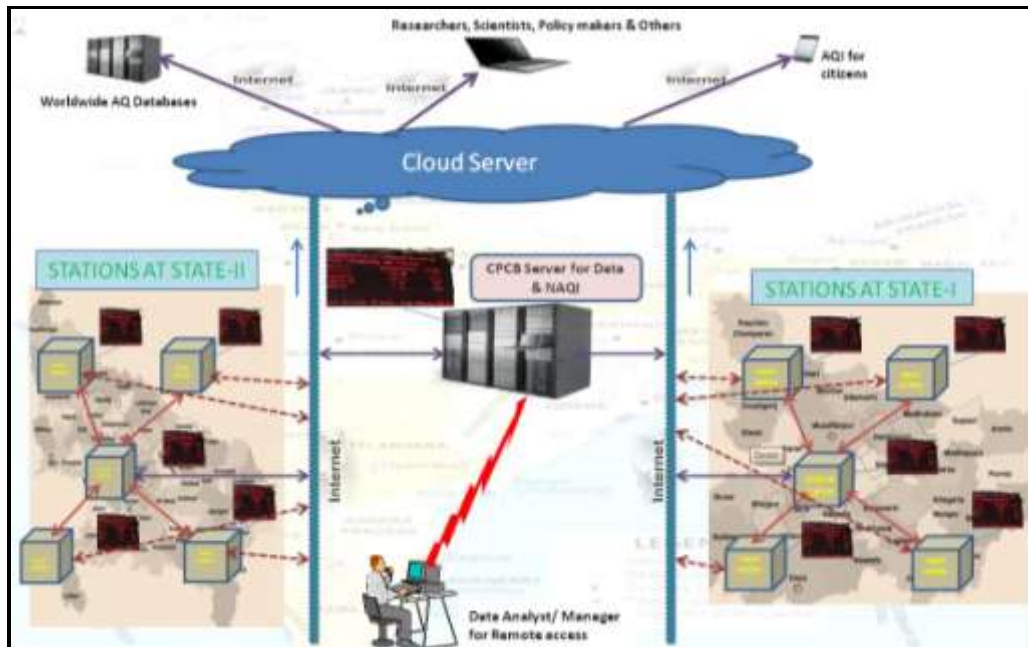

Central Pollution Control Board
East Arjun Nagar, Shahdara
Delhi - 110032.

CONTENTS

S.No.	Titles	Page Nos.
1.	CAAQM STATION – HOUSING/CONTAINER	7-10
1.1	Housing/Container for Continuous Ambient Air Quality Monitoring (CAAQM) Station including sampling system, internal fittings, instrument racks, electrical and gas line fittings, tools (electrical & mechanical), etc.	
2.	SPLIT AIR CONDITIONER (AC)	10-11
2.1	Split Air Conditioner (2 Ton Capacity)	
2.2	Split Air Conditioner (1 Ton Capacity)	
3.	ONLINE UNINTERRUPTED POWER SUPPLY (UPS)	11-12
3.1	Online UPS 10 KVA, capacity (Three Phase I/P and Single Phase O/P, with 01 hours backup) (for Air Conditioner)	
3.2.	Online UPS 5 kVA, capacity (Single Phase I/P & Single phase O/P, with 02 hrs backup) (01 for Analysers & 01 for Server at Central Station)	
4.	CONTINOUS AMBIENT AIR QUALITY MONTORING ANALYSER/SYSTEM	13-15
4.1	General Specification for all Analysers	
4.2	Sampling System	
4.3	19" Rack	
5.	CONTINOUS AMBIENT AIR QUALITY ANALYSER (GAS)	16-19
5.1	Ambient SO ₂ , Analyser	
5.2	Ambient NO-NO ₂ -NO _x , Analyser	
5.3	Ambient NH ₃ , Analyser	
5.4	Ambient CO, Analyser	

5.5	Ambient O ₃ , Analyser	
5.6	Ambient BTX, Analyser	
6.	CONTINUOUS AMBIENT AIR QUALITY MONITORING ANALYSERS (PARTICULATES)	19-21
6.1	Continuous PM ₁₀ Monitoring Analyser (β-RAY)	
6.2	Continuous PM _{2.5} Monitoring Analyser (β-RAY)	
6.3	Continuous PM ₁₀ and PM _{2.5} Monitoring Analyser (TEOM)	
7.	MULTI CALIBRATOR	22
7.1	Multi Point Gas Calibration System	
7.2	Meteorological, Flow and Electronics Calibration	
8.	METEOROLOGICAL SYSTEM	23-24
8.1	Meteorological System comprising of sensors for (A) Wind Speed, (B) Wind Direction, (C) Ambient Temperature, (D) Relative Humidity, (E) Solar Radiation & (F) Rainfall, mounted on (G) Telescopic Crank-up Meteorological Tower	
9.	DATA ACQUISITION AND COMMUNICATION SYSTEM	25-30
9.1	Typical Architecture for Data Connectivity	
9.2	Data acquisition and handling system at stations	
9.3	Work Station Computer at stations (for AQI Preparation)	
9.4	Manageable CISCO Switch (Rack Mountable)	

9.5	Remote Monitoring Tool/Software (For Stations and Central locations)	
9.6	42 U Industrial Rack (For Central Station at SPCB)	
9.7	Rack Server (For Central Station at SPCB)	
9.8	Access Point (AP) (For Central Station at SPCB)	
9.9	Unified Threat Management (UTM) device (For Central Station at SPCB)	
9.10	Connectivity for Data Transfer (Station)	
10.	DATA ACQUISITION SOFTWARE FOR STATION (CAAQM)	31-33
11.	DATA ACQUISITION SOFTWARE FOR CENTRAL STATION AT SPCB	33-36
12.	DISPLAY BOARD DATA TRANSMISSION DEVICE (ONE AT CAAQM STATION AND ONE AT SPCB)	36
13.	DAY LIGHT & NIGHT VISIBLE DATE DISPLAY SYSTEM	37-38
14.	Annexures	39-43
	<ul style="list-style-type: none"> a) DRAWING OF A CAAQM STATION b) Architecture of CAAQM System c) Data Communication Protocol 	

SCHEDULE OF REQUIREMENTS

The equipment's are intended for one Continuous Ambient Air Quality Monitoring (CAAQM) Station. The system should be completely functional. Any balance of material not specified but required for the purpose must be supplied by the vendors.

Brief Description	Qty. in Nos.
CAAQM STATION – HOUSING/CONTAINER	
Housing/Container for Continuous Ambient Air Quality Monitoring (CAAQM) Station including sampling system, internal fittings, instrument racks, electrical and gas line fittings, tools (electrical & mechanical), etc.	1 Unit
SPLIT AIR CONDITIONER (AC)	
Split Air Conditioner (2 Ton Capacity)	2 Unit
Split Air Conditioner (1 Ton Capacity)	1 Unit
ONLINE UNINTERRUPTED POWER SUPPLY (UPS)	
Online UPS 10 KVA, capacity (Three Phase I/P and Single Phase O/P, with 01 hrs backup) (for Air Conditioner)	1 Unit
Online UPS 5 kVA, capacity (Single Phase I/P & Single phase O/P, with 02 hrs backup) (01 for Analysers & 01 for Server at Central Station)	2 Unit
CONTINUOUS AMBIENT AIR QUALITY MONITORING ANALYSER/SYSTEM	
General Specification for all Analysers	
Sampling System	1 Unit
19" Rack	3 Unit
CONTINUOUS AMBIENT AIR QUALITY MONITORING ANALYSERS (GAS)	
Ambient SO ₂ , Analyser	1 Unit
Ambient NO-NO ₂ -NO _x , Analyser	1 Unit
Ambient NH ₃ , Analyser	1 Unit
Ambient CO, Analyser	1 Unit

Brief Description	Qty. in Nos.
Ambient O ₃ , Analyser	1 Unit
Ambient BTX, Analyser	1 Unit
CONTINUOUS AMBIENT AIR QUALITY MONITORING ANALYSERS (PARTICULATES) (1A. & 1B. OR 2.)	
1A. Continuous PM ₁₀ Monitoring Analyser(β-RAY)	1 Unit
1B. Continuous PM _{2.5} Monitoring Analyser(β-RAY)	1 Unit
2. Continuous PM ₁₀ and PM _{2.5} Monitoring Analyser (TEOM)	1 Unit
MULTI CALIBRATOR	
Multi Point Gas Calibration System	1 Unit
Meteorological, Flow and Electronics Calibration	1 Unit
METEOROLOGICAL SYSTEM	
Meteorological System comprising of sensors for (A) Wind Speed, (B) Wind Direction, (C) Ambient Temperature, (D) Relative Humidity, (E) Solar Radiation & (F) Rainfall, mounted on (G) Telescopic Crank-up Meteorological Tower	1 Unit
DATA ACQUISITION AND COMMUNICATION SYSTEM	
Data acquisition and handling system at stations	1 Unit
Work Station Computer at stations (for AQI Preparation)	1 Unit
Manageable CISCO Switch (Rack Mountable)	1 Unit
Remote Monitoring Tool/Software (For Stations and Central locations)	1 Unit

Brief Description	Qty. in Nos.
42 U Industrial Rack (For Central Station at SPCB)	1 Unit
Rack Server (For Central Station at SPCB)	1 Unit
Access Point (AP) (For Central Station at SPCB)	1 Unit
Unified Threat Management (UTM) device (For Central Station at SPCB)	1 Unit
Connectivity for Data Transfer (Station)	1 Unit
DATA ACQUISITION SOFTWARE FOR STATION (CAAQM)	1 Unit
DATA ACQUISITION SOFTWARE FOR CENTRAL STATION AT SPCB	1 Unit
DISPLAY BOARD DATA TRANSMISSION DEVICE (ONE AT CAAQM STATION AND ONE AT SPCB)	2 Unit
DAY LIGHT AND NIGHT VISIBLE DATA DISPLAY SYSTEM (ONE AT CAAQM STATION AND ONE AT SPCB)	2 Unit

TECHNICAL SPECIFICATIONS

1. CAAQM STATION –HOUSING/ CONTAINER

1.1 Housing/Container: It is designed for housing the ambient air quality monitoring instruments to protect them from dust and heat. Temperature and Humidity sensors shall be installed in the housing for checking the humidity and temperature inside the station. Three Nos. 19" racks shall be installed inside the station so that the analyzers are easily accessible from front & back for calibration and maintenance.

1.1.1 Dimensions: Inside length: 4200 mm
Inside width: 3500 mm
Inside height: 2500 mm
(As per the Drawing given)

1.1.2 Frame: All the material used for the construction of the floor, frame, roof frame etc, the 4 corner posts and 8 integrated, reinforced container corners should be of metal. The exterior panel of the container shall be made of pre-coated MS Sheet of approved colour shade. All other steel parts should be hot dipped galvanized having minimum rate of galvanization of 275 gram per square meter (**IS277**). All joints of like metal such as steel-to-steel or aluminum-to-aluminum shall be protected against corrosion by liberal application of joining compound. All joints of dissimilar metals such as steel to aluminum shall be protected against corrosion due to galvanic action by liberal application of dielectric compound as well as jointing compound on both mating surfaces. For lifting / fixing the container, International Standard eyebolts should be provided at the corners.

1.1.3 Paneling: The outer paneling will be of 1.2 mm of Pre-coated MS sheet to withstand external impacts and abrasions. Outer side of the MS Sheet i.e. exposed face of the sheet, shall be permanently colour coated with silicon modified polyester coating of dry film thickness (DFT) 20 micron (min.) of approved colour shade over primer. Inner face of the sheet shall be provided with suitable pre-coating of minimum 7 micron off-white colour. The inner paneling will be of PVC coated 2 mm thick aluminum sheet, fixed over an inlay of 4 mm marine plywood. 100 mm thick polyurethane insulation will be used between the outer and inner walls (Pre-coated MS sheet and Marine plywood) as insulating material. Z spacers if required shall be made out of at least 2 mm thick galvanized steel sheet of grade 275 as per IS:277

1.1.4 Floor:The floor will be laid in frame of 600 x 600 mm centre to centre with 50 x50 x 6 mm MS angle. The floor surface will be of 19 mm marine plywood covered with robust quality Vinyl flooring, 2 mm thick of approved colour. The floor should be of acid and alkaline resistant, waterproof, easily cleanable / washable. Bottom plate of thickness 2 mm hot dipped galvanised MS Plate shall be provided.

1.1.5 Outer Door: One door of size 2000 x 900 mm will be provided at the front side (L = 4200 mm) of the station with isolated 3 – point locking & door handle flush fitted.

1.1.6 Electric Power Supply Box: Three - phase (3 Ø) electrical wiring will be laid in ducts. Copper wiring of appropriate gauge will be used. The terminal board should be mounted in a central power distribution box. Over voltage protection for each phase shall be provided along with the lightning arrester. 2 numbers Emergency cut off switch & Thermostat switch (max 35°C) for power disconnection, 6 free sockets and 3 fluorescent lamps for lighting will be provided.

The station shall be properly grounded with chemical earthing or as per BIS Standards with proper plate and only copper strip at least on 2 corners (diametrically opposite). One three phase energy meter (Digital Type) shall be installed. Weatherproof cubicles / enclosure for housing of MCB / TP & N Switch of main power termination (outside shelter) and weatherproof telephone junction box for terminations of telephone line are to be provided. Proper earthing for telescopic mast of meteorological system shall be provided. There should be conduction between the telescopic mast of the meteorological system and the station. The guy ropes or wires shall be provided for supporting the mast.

List of Consumables:

All Fuses	: 02 set
Lightning arrestor	: 02 set
Emergency Switch	: 02 pcs
Thermostat	: 01 pc

1.1.7 Partitioning for Calibration Gas Cylinders, Meteorological Mast and UPS:

The housing will be partitioned as per drawing to create space for storing of gas cylinders, Meteorological mast & UPS. The size will be 2000 x 1400 x 2300 mm. A lockable door of size 900 x 2000 mm along-with 3 – Point locking system shall be provided on the outer wall of the housing. A 300 mm, single-phase (230 volts ± 10 volts AC and 50 Hz ± 3%) exhaust fan with safety grills will be provided. Mounting brackets in 2 levels for fixing of at-least 06 (six) gas cylinders should be provided. The internal lights of the housing should be sensor based.

Air conditioners shall be mounted on proper rust proof supporting structures with rubber blocks to avoid vibration of structures. Proper caging / grill should also be provided for the safety of ACs. Sun shades for external AC units shall be provided with fabricated pre-coated MS sheet (same as monitoring station) with supporting arrangements. AC unit's external piping shall be placed in GI trays. Cable trays fixed on exterior wall shall be covered with pre-coated MS sheet, of same colour shade of monitoring station. Roof top sheet to be levelled and sloped properly. Rain water spout shall be fixed at top with rain water down pipe at two corners. The external lights of the station should be Solar operated.

1.1.8 Station Furnishing:

- (i) 19" racks – 03 Nos.
- (ii) Fire extinguishers – 02 Nos. (Clean Agent – 2 KG each)
- (iii) Furniture:
 - a) Material - Furniture made of water resistant laminated board
 - b) Cupboard – As per drawing
 - c) Working table – Powdered coated MS frame size 1400 x 900 x 750 mm (w x d x h) and top 19 mm thickness Board
 - d) Revolving tilting chair – 02 Nos.
- (iv) Miscellaneous
 - a) The exhaust gases from the analyser should be collected and discharged by a common exhaust pipe and vented.
 - b) Folding aluminium ladder for roof access (Length.... with 1 feet width steps)

- c) Sensor for measuring the inside temperature of the station and Display
- d) Hygrometer for measurement of Humidity inside the station and Display
- e) Mounting bracket for the ladder
- f) No smoking stickers
- g) Vacuum cleaner with minimum 100 watt power
- h) Tool Kit having following tools:
 - 1. One screw driver set
 - 2. One Digital multi-meter (Philips, Micro or equivalent make)
 - 3. One box spanner set
 - 4. One D spanner set
 - 5. One watch maker set
 - 6. One Hammer set
 - 7. One precision screw driver set
 - 8. One pliers set
 - 9. One Tong tester
 - 10. One Soldering Iron with stand
- i) One Emergency LED Cluster light
- j) Sign boards along-with logo of Central Pollution Control Board, Delhi / State Pollution Control Board, to be embedded with size 1500 x 900 mm on the front of the container and on the two side of the container, The name of the Station i.e. Continuous Ambient Air Quality MONITORING Station, (Location) both in English and Hindi or local language to be inscribed. The Signs boards to be mounted on the station with proper spacers.

1.1.9 Container Foundation (RCC)

L X W 6000 x 6000 mm

Height 300 mm from ground

Pillars: Nine concrete pillars of 300 mm above the ground level and below the ground level with 200 x 200 mm beam and between pillar bricks to be used for filling the space(**concrete ratio of 1:2:4**). Outer wall of the foundation to be plastered with 1:4, Cement: Sand ratio and same has to be painted with weather proof coat.

Top of the platform: RCC 150 mm with concrete ratio of 1:1:2 and to plaster and painted with weather proof paint.

Staircase: RCC Steps to approach the main door of the container and the UPS / Gas room door in the side to be provided and each step should not be more than 150 mm

1.1.10 Security Cabin

A 4 feet x 4 feet wooden / Paneled security cabin with chair and small folding table for security guard with covered overhead selves to be provided separately with the station container.

2. SPLIT AIR CONDITIONER

2.1 SPLIT AIR CONDITIONER (2.0 TON CAPACITY)

2.1.1 Type & Capacity: 2 Nos. split type, 2 ton capacity AC, roof mounted of 5 star rating with an automatic timer. Separate Automatic Voltage stabilizer will be provided with each unit.

2.1.2 The indoor units should be running alternately at an interval of four hours with timer control and the temperature inside the station should be maintained at 25⁰ C inside during all the time including peak summer months.

- a. Cooling Capacity:7000 W
- b. Star Rating: BEE 5 star
- c. Indoor Noise Level: 40db
- d. Control Type: Remote
- e. Compressor: Rotary
- f. Refrigerant: Eco Friendly
- g. Feature: filter clean Indicator, defrosting Sensor
- h. Power supply: 230 volts \pm 10volts AC and 50 Hz \pm 3%
- i. Standard Warranty
- j. Remote: LCD Wireless.

2.2 SPLIT AIR CONDITIONER (1.0 TON CAPACITY)

2.2.1 Type & Capacity: 1 Nos. split type, 1 ton capacity AC, roof mounted of 5 star rating with an automatic timer. Separate Automatic Voltage stabilizer will be provided with each unit.

2.2.2 The indoor units should be running alternately at an interval of four hours with timer control and the temperature inside the station should be maintained at 25⁰ C inside during peak summer months.

- a) Cooling Capacity:3400 W

- b) Star Rating: BEE 5 star
- c) Indoor Noise Level 40db
- d) Control Type: Remote
- e) Compressor: Rotary
- f) Refrigerant: Eco Friendly
- g) Feature: filter clean Indicator, Pre-coated Aluminium fins etc.
- h) Power supply: 230 volts \pm 10volts AC and 50 Hz \pm 3%.
- i) Standard Warranty
- j) Remote: LCD Wireless.

3. ONLINE UNINTERRUPTED POWER SUPPLY (UPS)

3.1 ONLINE UPS 10 kVA, CAPACITY (Three Phase I/P & Single Phase O/P, with 01 hours backup) (for Air Conditioner)

Three phase 10 kVA UPS along with Automatic Delayed Restoration Device (ADRD) with 1 hour backup in full capacity should be provided for the smooth operation of one 2 Ton capacity split AC at the station.

- | | | | |
|----|-----------------------|---|--|
| a) | Capacity | : | 10.0 kVA |
| b) | Technology | : | PWM using IGBT / MOSFETS |
| c) | Crest Factor | : | More than 3: 1 |
| d) | Input | | |
| | Voltage | : | 415 V AC |
| | Voltage Range | : | \pm 25% |
| | Frequency | : | 50 Hz \pm 3% |
| e) | Output | | |
| | Voltage | : | 230 V AC |
| | Voltage regulation | : | \pm 1% |
| | Frequency | : | 50 Hz |
| | Frequency regulation | : | \pm 0.01% |
| | Waveform | : | Pure sine wave |
| f) | Battery | | |
| | Battery type | : | Sealed maintenance free |
| | Back up time | : | 1 Hour at full load |
| | Battery Capacity | : | For required backup time |
| | Recharge time | : | 5 hrs to 90% after complete discharge |
| g) | Distortion | : | Less than 1% on linear load |
| h) | Power factor | : | 0.9 to 1 |
| i) | Indicator | : | L.E.D. – Battery Charge, Load level, on Line, over load, on battery, replace battery |
| j) | Alarm | : | Audible alarm for battery backup, battery low, and fault |
| k) | Protections | | |
| | Surge | : | Surge suppression meets BIS or International standard |
| | Overload | : | Fuse & current limited |
| | Short circuit | : | Fuse & current limited & cut – off |
| | Battery low cut – off | : | No battery drain after cut - off |
| l) | Overload Capacity | : | 110% for continuous load |
| m) | Efficiency | : | More than 90% |
| n) | Environment | | |
| | Operating Temp. | : | 0 – 50 ^o C |

Operating Hum. : 10% to 95% (Non condensing)
 Audible Noise : Less than 45 db (at 1 meter)

3.2 ONLINE UPS 5 KVA, CAPACITY (Single Phase I/P & Single phase O/P, with 02 hours backup) (01 for Analysers & 01 for Server at Central Station) :-

Single phase 5 kVA UPS along with Automatic Delayed Restoration Device (ADRD) with 2 hours backup in full capacity should be provided for the smooth operation of Analyzers and peripherals at the station:

3.2.1	Capacity	:	5.0 kVA
3.2.2	Technology	:	PWM using IGBT / MOSFETS
3.2.3	Crest Factor	:	More than 3: 1
3.2.4	Input		
	Voltage	:	230 V AC
	Voltage Range	:	± 25%
	Frequency	:	50 Hz ± 3%
3.2.5	Output		
	Voltage	:	230 V AC
	Voltage regulation	:	± 1%
	Frequency	:	50 Hz
	Frequency regulation	:	± 0.01%
	Waveform	:	Pure sine wave
3.2.6	Battery		
	Battery type	:	Sealed maintenance free
	Back up time	:	2 Hours at full load
	Battery Capacity	:	For required backup time
	Recharge time	:	5 hrs to 90% after complete discharge
3.2.7	Distortion	:	Less than 1% on linear load
3.2.8	Power factor	:	0.9 to 1
3.2.9	Indicator	:	L.E.D. – Battery Charge, Load level, on Line, over load, on battery, replace battery
3.2.10	Alarm	:	Audible alarm for battery backup, battery low and fault
3.2.11	Protections		
	Surge	:	Surge suppression meets BIS or International standard
	Overload	:	Fuse & current limited
	Short circuit	:	Fuse & current limited & cut – off
	Battery low cut – off	:	No battery drain after cut - off
3.2.12	Overload Capacity	:	110% for continuous load
3.2.13	Efficiency	:	More than 90%
3.2.14	Environment		
	Operating Temp.	:	0 – 50 ⁰ C
	Operating Humidity	:	10% to 95% (Non condensing)
	Audible Noise	:	Less than 45 db (at 1 meter)

4. CONTINUOUS AMBIENT AIR QUALITY MONITORING ANALYSERS for SO₂, NO-NO₂-NO_x, NH₃, CO, O₃ and BTX

4.1 (General Specifications for all Analysers)

- 4.1.1 The analyzers should be 19" rack mounting model with facilities for fixing the analyzers from front side.
- 4.1.2 The front panel should have ON / OFF Switch.
- 4.1.3 The display of the entire important status signal viz. Sample flow, temperature, concentration, range selection, manual / auto mode, zero / span mode and all error messages should be on front panel.
- 4.1.4 The analyzers should operate at operating voltage 230 volts \pm 10 volts AC and 50 Hz \pm 3% frequency. The power supply input to be protected against spikes from and to the analyzer by an LC filter. The power connection cable should be CEE type complete with 15 Amperes plug adaptable to Indian mains socket.
- 4.1.5 The analyzers must function properly in Indian conditions without any defect between 0 – 50° C ambient temperature, 10 – 95% relative humidity and in high ambient dust levels. The data capture rate should not be less than 90% of operational time.
- 4.1.6 The Manufacturer shall provide comprehensive hands-on training for operational & preventive maintenance for one week in the respective State for three persons per station.
- 4.1.7 The analyzers should complete with calibration system. The calibration system should be delivered along-with respective span gas cylinder and permeation tubes. The span gas concentration should be within 60 – 90% of first measuring range. The analyzer must have zero point internal calibration system and in agreement with minimum detection limit of each analyzer. The calibration procedures are to be integrated into the software system for automatic calibration & remote calibration.

PERMEATION TUBE

- 4.1.8 The analyzer of SO₂, NO-NO₂-NO_x, NH₃ & BTX should have the permeation bench with NIST certified permeation tube for the span check in the analyzer. The date of Calibration Certificate of Permeation Tube should not be older than 30 days on the date of commissioning of the respective analyzer. Thus, it is desirable that the consignment of permeation tubes may be dispatched separately.

CALIBRATION GAS CYLINDER

- 4.1.9 The supplier has to supply the calibration gas cylinder (highly polished aluminium 10 liters water capacity), along with SS Regulator, traceable to NIST for each components (SO₂, NO, CO, NH₃, Benzene & Toluene) along with SS regulator for the multipoint calibration. The synthetic air and N₂ cylinder (99.99% purity with certificate) should be in Carbon Steel cylinder of 47 Liters water capacity along with SS Regulator.
- 4.1.10 The analyzers shall be supplied with all ancillaries necessary for operation with pump (preferably in built) and any other items such as charcoal scrubber, Teflon air sample intake filter, drier, Teflon tubing suitable for connection to air sampling manifold. All such items are to be itemized. Dust filter in all the analyzers should be provided before solenoid valve to protect frequent chocking of solenoid valve.
- 4.1.11 The connector systems for out-going signal for recording and the computer terminal should be on back panel with screw type connecting pins.
- 4.1.12 All ambient gas analyzers shall be approved by the USEPA / TUV / MCERTS / EN. However, in case of BTX and Ammonia Analyzer specifications as given will be considered. Method of measurement used shall also comply with the stipulation on National Ambient Air Quality Standards (NAAQS) 2009 (Details of Methods of Measurement is available at MoEF and CPCB websites). All analyzers shall be micro – processor controlled with automatic calibration using an external dilution calibrator and calibration standards. All analyzers should be fully integrated in the rack cabinet, fully calibrated & tested before supply and ready for start – up at the

respective sites. Analyzer must exhibit performance equal to or better than values specified in the Calibration & test certificate provided with each analyzer.

4.1.13 The manufacturer shall specify the cross sensitivity of measurement for all the analyzers.

4.1.14 Each set of analyzers shall be supplied with two copies of elaborate operation manuals comprising details as below:

Parts (I) should comprise installation, operational and troubleshooting details;

Parts (II) should have details about preventive, routine and corrective maintenance;

Parts (III) should comprise details of all electrical, electronic and pneumatic circuit diagrams, details of each spare parts, catalogue No. etc. and details of each electronic card / PCB's; and

Parts (IV) Schematic diagram for possible repair & maintenance.

Parts (V) Standard Operating Procedure (SOP) for each analyzer.

Parts (VI) List of equipments and other accessories along with contact details of supplier.

4.1.15 Digital Output:

a) Multi drop RS 232 port shared between gas Analyzers, Dust Analyzer (PM_{2.5}& PM₁₀), Meteorological Sensors and computer for data, status and control. Communication should have a USB port, TCP/IP Ethernet connection

4.1.16 Quality Control and Standard

Data shall be collected and validated according to US EPA standards, using the methodologies included in 40 Code of Federal Regulations. All analyzers shall have current US EPA reference or equivalent method designation and shall be of the latest design.

The supplier shall submit a Standard Operating Procedure for the air quality monitoring stations to the Buyer at the time of bid submission. This Standard Operating Procedure shall be approved by the Buyer prior to award. The Standard Operating Procedure shall contain the following:

- i. Operating procedures for all analyzers and meteorological sensors
- ii. Calibration procedures
- iii. Calibration schedule
- iv. Maintenance procedures
- v. Maintenance schedule
- vi. Data validation procedures
- vii. Quality Assurance procedures
- viii. Sample quality assurance documentation
- ix. Sample Air Quality Report

The calibration procedures for analyzers shall conform to US EPA methodologies and shall include daily calibration checks, by weekly precision checks and linearity checks every six weeks. All analyzers shall undergo full calibration in every three months. Data obtained from these calibration checks and copies of associated Quality Assurance and calibration documentation, shall be submitted to the Buyer along with the Air Quality Data.

Air Quality Data shall be submitted to the Buyer on Real Time basis through automated system and on a monthly basis in the form of an Air Quality Report. This report shall include tabular and graphic information on gas and dust

concentrations as well as meteorological data for each site. The data shall be reported in the form of 15 minute averages and shall also include daily, weekly and monthly averages, minimum, maximum, standard deviations, total data captured and percent data capture. It should also have stat validation mechanism and delayed data check mechanism. The Air Quality Report shall also include wind roses where wind speed and direction are measured.

Upon 24 hour notice from the Buyer, once per year, the supplier shall agree to submit to an audit of calibrations, conducted, using pre-approved US EPA methodologies, by a third party. The results of these audits shall be made immediately available to both the supplier and Buyer.

4.2 SAMPLING SYSTEM

A suitable sampling system as specified by USEPA having 10 ports manifold and fitted with a suction pump to draw ambient air. System duly equipped with moisture removal systems should be provided for sampling of ambient air separately for gaseous and dust measurement.

Gases sampling system:

- | | | |
|-------|--------------------------------|---|
| 4.2.1 | Height of the sampling system: | Approx. 1.0 meter above the roof |
| 4.2.2 | Roof entry cut out: | Stainless Steel |
| 4.2.3 | Conduit: | Stainless Steel |
| 4.2.4 | Inner sampling system: | Borosilicate glass |
| 4.2.5 | Sampling head: | Stainless Steel |
| 4.2.6 | Manifold: | 10 port for tubes 6 x 1 mm, self-tightening. |
| 4.2.7 | Sample air flow sensor | Uni-directional sample air flow measuring device should be installed at the sampling system to measure the flow of ambient air through sampling system. The output of signal should be connected to computer to ascertain the continuous flow of sample from ambient air. The suction pump operational status should also be connected to the computer as a separate channel. |

4.3 19" RACK

Suitable 19" Rack cabinet to accommodate all analyzers, calibrators, Zero air generators, data logger etc. The dimension of the rack without doors, with aluminum section and rear of 2 mm steel sheet, one removable roof plate, fitted with 4 filling eyebolts. Four roof fixing screws included in package to replace the lifting eyebolts. One gland plate three part, one pair of 475 mm (19") mounting angles depth adjustable in 25 mm pitch pattern fitted on two fixing angles approximately 150 mm unit from the front standard. To accommodate panel width of 19" size: width = 600 mm, Height = 1400 mm and Depth = 800 mm. The 19" racks should be screwed to the floor of the station with anti-vibration pads. All nuts and bolts shall be cadmium coated.

5. AMBIENT AIR QUALITY MONITORING ANALYSERS (GAS)

5.1 AMBIENT SULPHUR DIOXIDE (SO₂) ANALYSER

01.	Principle	:	Pulsed UV Fluorescence
02.	Measurement	:	SO ₂ in Ambient Air
03.	Display	:	Digital
04.	Ranges	:	Auto ranging 0 - 200 ppb
05.	Lower Detectable Limit	:	1 ppb
06.	Noise Level	:	0.5 ppb
07.	Zero Drift	:	< 1 ppb/24 Hrs. with automatic zero compensation
08.	Span Drift	:	<1 ppb in 24 hrs.
09.	Linearity	:	± 1% of full scale
11.	Response Time	:	120 sec or less
12.	Span check facility	:	Built in permeation bench
13.	Calibration	:	Please see Multi-calibration section (Sl. No. 7) and also calibration section in General Specifications(4.1.7 to 4.1.9)
14.	Analog Output	:	0 – 1 V, 0 – 10 V, 2 – 20 mA / 4 – 20 mA
15.	Digital Output	:	Multiple drop RS 232, USB port /TCP/IP ,Ethernet

5.2 AMBIENT OXIDES OF NITROGEN (NO-NO₂-NO_x) ANALYSER

01.	Principle	:	Chemiluminescence
02.	Measurement	:	NO-NO ₂ - NO _x in Ambient Air
03.	Display	:	Digital
04.	Ranges	:	Auto ranging 0-2000 ppb
05.	Lower Detectable Limit	:	1 ppb
06.	Noise Level	:	0.5 ppb
07.	Zero Drift	:	< 1 ppb/24 Hrs.
08.	Span Drift	:	< 2% in 15 days of full scale
09.	Linearity	:	± 1% of full scale
10.	Response Time	:	120 sec or less
12.	Span Check	:	Built in permeation bench
13.	Calibration	:	Please see Multi-calibration section (Sl. No. 7) and also calibration section in General Specifications (4.1.7 to 4.1.9).
14.	Analog Output	:	0 – 1 V, 0 – 10 V, 2 – 20 mA / 4 – 20 mA
15.	Digital Output	:	Multi drop RS 232 port, USB port /TCP/IP ,Ethernet

5.3 AMBIENT AMMONIA ANALYSER (NH₃)

01.	Principle	Chemiluminescence (NH ₃ conversion to NO by oxidation. NO ₂ also converted to NO. The difference obtained by measuring NO in output of two sample stream as equal to NH ₃)
02.	Measurement	NH ₃ in Ambient Air
03.	Display	Digital
04.	Ranges	Auto ranging 0-1000 ppb
05.	Lower Detectable Limit	1 ppb

06.	Noise Level	0.2% of reading
07.	Zero Drift	<5 ppb /24 Hrs.
08.	Span Drift	< 2% in 15 days of full scale
09.	NH ₃ /NO converter	Quartz at approx. 1000 ⁰ C
10.	Linearity	± 1% of full scale
11.	Response time	180 second
12.	Rise / fall Time (95% of the final value)	< 30 Sec
13.	Span Check facility	Built in permeation bench
14.	Calibration	Please see Multi-calibration section (Sl. No. 7) and also calibration section in General Specifications (4.1.7 to 4.1.9).
15.	Analog Output	0 – 1 V, 0 – 10 V, 2 – 20 mA /4 – 20 mA a
16.	Digital Output	Digital output Multi drop RS 232 port, USB port /TCP/IP ,Ethernet

5.4 AMBIENT CARBON MONOXIDE (CO) ANALYSER

01.	Principle	:	Non Dispersive Infra-Red (NDIR) with Gas Filter Correlation
02.	Measurement	:	CO in Ambient Air
03.	Display	:	Digital
04.	Ranges	:	Auto ranging 0 - 100 ppm.
05.	Lower Detectable Limit	:	0.1 ppm
06.	Noise Level	:	0.05 ppm with time constant ± 30 seconds
07.	Zero Drift	:	< 0.2 ppm/7 days
08.	Span Drift	:	< 1% full scale in 24 hrs.
09.	Linearity	:	Continuous ± 1%
10.	Response Time	:	30 seconds or less
11.	Calibration	:	Please see Multi-calibration section (Sl. No. 7) and also calibration section in General Specifications (4.1.7 to 4.1.9).
12.	Analog Output	:	0 – 1 V, 0 – 10 V, 2 – 20 mA / 4 – 20 mA
13.	Digital Output	:	Multiple drop RS 232port, USB port /TCP/IP ,Ethernet

5.5 AMBIENT OZONE (O₃) ANALYSER

01.	Principle	:	UV Photometric / Chemiluminiscence
02.	Measurement	:	O ₃ in Ambient Air
03.	Display	:	Digital
04.	Range	:	Auto ranging 0 - 500 ppb
05.	Lower Detectable Limit	:	1.0 ppb
06.	Noise level	:	± 0.5 ppb
07.	Zero Drift	:	< ½% per month
08.	Span Drift	:	< 1% per month
09.	Linearity	:	Continuous ± 1%
10.	Response Time	:	30 seconds or less
11.	Calibration	:	With built in Zero and span generator and also see Multi-calibration section (Sl. No. 7)
12.	Analog Output	:	0 – 1 V, 0 – 10 V, 2 – 20 mA / 4 – 20 mA
13.	Digital Output	:	Multiple drop RS 232 port, USB port /TCP/IP ,Ethernet

5.6 AMBIENT BTX ANALYSER

5.6.1 GENERAL

A complete analyzer system comprising of sampling pump, transfer line, analyzer, detector, calibrator, computer hardware and software for instrument control, data storage, display, acquisition, processing and for selective determination of volatile compounds in ambient air optimized for Benzene, Toluene, Ethyl Benzene and o, m, p -Xylenes. Continuous unattended measurement system of individual BTX should work without external cryogenic cooling. System should have protocol compatible to communicate & transfer data to DAS. Raw data storage capacity without erase minimum for three month or more. The system should be delivered with all necessary spares, consumables, tubing etc. for making it functional.

5.6.2 TECHNICAL SPECIFICATIONS

A single stage membrane Pump collect ambient sample automatically an inbuilt adsorption trap. Subsequent, the sample will be dissolved and injected on wide bore capillary gas chromatographic separation. Sample volume controlled by thermal mass flow controller (dust protected). Sample flow range may be 20 -100 ml/min or more (adjustable). Sample volume should be between 400 ml – one liter or more of ambient air over a 10-15 min sampling cycle. All sample transfer tubing should be in stainless steel and flow & pressure sensor to be preferred with digital display.

5.6.3 DETECTOR

Photo Ionization Detector (**PID**) or other equivalent detector **as per EPA/EU/TUV/MCERT** approved specifications, which do not require hydrogen or other gas to operate it. The system should have auto-clean & auto calibration facilities. PID Lamp eV should be 10.6 eV. PID sensitivity sensor should be available to check sensitivity.

5.6.4 MINIMUM SPECIFICATIONS

Principal	:	Based on gas Chromatographic separation and Photo Ionization Detector (PID)
Measurement	:	Benzene, Toluene, Ethyl-benzene, m.p-Xylene and O-Xylene.
Display	:	Digital
Range	:	0 - 100 ppb (0.32 – 325 μ g/m ³)
Lower detectable limit	:	0.2 ppb (0.65 μ g/m ³) for 15 min cycle for Benzene
Temperature Range	:	5 - 35°C or more
Repeatability	:	Retention Time : <0.1% RSD Concentration: <1.0% RSD
Typical Cycle Time	:	Total Cycle Time should not exceed 15min i.e. Sample Collection Time -15 min approx. Analytical Time- 15 min approx.
Sample Volume	:	1 liter for 15 min cycle.
Desorption tube	:	Carbotrap
Pre concentration	:	Carbopack
Span Check	:	Built in permeation bench with NIST certified Benzene& Toluene permeation tube.
Calibration	:	The Analyzer should be capable to calibrate through

		Multi Calibration System also. Please see Multi-calibration section (Sl. No. 7) And also calibration section in General Specifications (4.1.7 & 4.1.9).
Analog Output	:	0 – 1 V, 0 – 10 V, 2 – 20 mA / 4 – 20 mA
Digital Output	:	Multi drop RS 232 port, USB port /TCP/IP ,Ethernet

6. CONTINUOUS AMBIENT AIR QUALITY MONITORING ANALYSERS (PARTICULATES)

6.1 CONTINUOUS PM₁₀ MONITORING ANALYSER (β-RAY ATTENUATION)

Based on the principle of β-ray attenuation, particulate sampled through the instrument and collected on fiberglass filter tape. Before and after sampling, β-ray radiation is measured by scintillation / G.M. counter. An internal microprocessor handles all sequences and automatically calculates the concentration of PM₁₀.

01.	Principle	:	β-ray attenuation
02.	Particle Size Cut Off	:	0 - 10 Microns
03.	Measuring Range	:	User selectable (0 – 500, 0 – 1000 & 0 -2000 μg/m ³) with auto ranging feature
04.	Resolution	:	1% of the measurement range
05.	Lower Detectable Limit	:	2 μg/m ³
06.	Detector	:	Plastic Scintillator / GM Counter
07.	Air Flow Rate	:	At least 1.5 m ³ / hr
08.	Filter Material	:	Glass Fiber Filter
09.	Display	:	LED / LCD
10.	Sampling Head	:	Dynamic heated sampling head for measurement of PM ₁₀ , with adjustable temperature 20 – 70 °C
11.	Calibration	:	Reference membrane facility should be provided for calibration of analyzer.
12.	Compatibility	:	Analyzer should be compatible with protocols of DAS system to be used in station.
13.	Analog Output	:	0 – 1 V, 0 – 10 V, 2 – 20 mA / 4 – 20 mA
14.	Digital Output	:	Multi drop RS 232 port USB port /TCP/IP /Ethernet
15.	Roll Length	:	Minimum 20 meters
14.	Measurement interval	:	1min. to 60 minute (user selectable) Generally measurement shall be done at a frequency of 15 minutes.

6.2 CONTINUOUS PM_{2.5} MONITORING ANALYSER (β-RAY ATTENUATION)

Based on the principle of β-ray attenuation, particulate sampled through the instrument and collected on fiberglass filter tape. Before and after, sampling β-ray radiation is measured by scintillation / G.M. counter. An internal microprocessor handles all sequences and automatically calculates the concentration of PM_{2.5}.

01.	Principle	:	β-ray attenuation
02.	Particle Size Cut Off	:	0 – 2.5 Microns
03.	Measuring Range	:	User selectable (0 – 500, 0 – 1000 & 0 -2000 μg/m ³) with auto ranging feature
04.	Resolution	:	1% of the measurement range
05.	Minimum Detectable Limit	:	2 μg/m ³

06.	Detector	:	Plastic Scintillator / GM Counter
07.	Air Flow Rate	:	At least 1.5 m ³ / hr.
08.	Filter Material	:	Glass Fiber Filter
09.	Display	:	LED / LCD
10.	Sampling Head	:	Dynamic heated sampling head for measurement of PM _{2.5} with adjustable temperature 20 – 70 °C
11.	Calibration	:	Reference membrane facility should be provided for multipoint calibration of analyzer.
12.	Compatibility	:	Analyzer should be compatible with protocols of DAS system to be used in station.
13.	Roll Length	:	Minimum 20 meters
14.	Analog Output	:	0 – 1 V, 0 – 10 V, 2 – 20 mA / 4 – 20 mA
15.	Digital Output	:	Multi drop RS 232 port ,USB port /TCP/IP ,Ethernet
16.	Measurement Interval	:	1min. to 60 minute (user selectable) Generally measurement shall be done at a frequency of 15 minutes.

6.3 AMBIENT PARTICULATE ANALYSER (PM₁₀ & PM_{2.5}) BASED ON THE PRINCIPLE “TAPERED ELEMENT OSCILLATING MICROBALANCE” (TEOM) CONFORMING TO USEPA AUTOMATED FEDERAL EQUIVALENT METHOD (FEM) DESIGNATION (EQPM-0609-182/EQPM-0822-207/EQPM-0822-208)

SPECIFICATIONS

TEOM 1405-DF Ambient Particulate Analyzer (PM 2.5 & PM10) = Dual TEOM (FDMS)

Regulatory Designations

- Approval and Certificates: U.S. EPA approved PM_{2.5} equivalent Analyzer (EQPM-0609-182), USEPA PM₁₀-PM_{2.5} Equivalent Monitor (EQPM-0822-207), US EPA PM₁₀ and equivalent monitor (EQPM-0822-208) and TUV-PM_{2.5} and PM₁₀ equivalent monitor.

Standard System Configuration

- Menu-driven software for user interaction via 1/4 VGA display with touch screen
- Connecting and Interface Cables, and Vacuum Pump
- Consumables for average three year’s operation (ambient)
- RPCOMM and ePort Software for Local or Remote Communication

Instrument Performance

- Measurement Range: 0 to 1,000,000 µg/m³ (1 g/m³)
- Resolution: 0.1 µg/m³
- Precision: ±2.0 µg/m³ (1-hour average), ±1.0 µg/m³ (24-hour avg.)

3 l/min, 1s, stable conditions

- ±0.1 µg/m³ (24 hr average), accuracy for Mass Measurement: ±0.75%

Data Averaging and Output

- Real-time Mass Conc. Average: 1 hour rolling average updated every six minutes
- Long-Term Averaging: 1, 8, and 24 hr
- Data Output Rate: Selectable from 10 sec to 24 hour

Operating Range

- The temperature of the sampled air may vary between 40 °C and 60 °C. The TEOM Sensor and Control Units must be weather protected within the range of 8 to 25 °C. An optional Complete Outdoor Enclosure provides complete weather protection.

Sample Flow

- Activol flow control system uses the mass flow sensors and the measured ambient temperature and pressure to maintain constant volumetric flow rates.
- Main Flow Rate: Fine PM filter: 3.0 l/min; Coarse PM filter: 1.67 l/min
- Bypass Flow Rate: 12.0 l/min

Data Storage

- Internal data logging of user-specified variables; capacity of 500,000 records.

Filter Media

- Sample Filter: Pallflex TX40, 13 mm effective diameter
- Sample Conditioner Filter: 47 mm diameter housed in an FRM-style molded filter cassette, maintained at 4°C. Suitable for collecting and archiving time-integrated PM samples for subsequent laboratory analysis.

Sample Conditioning

- Sample Equilibration System (SES) dryer lowers the main flow relative humidity and allows for mass transducer operation at 5° cover the peak air monitoring station temperature
- Purge Filter Conditioner contains a heat exchanger that maintains the temperature of the main flow and particle filter at 4°C to efficiently filter the volatile and non-volatile PM in the sample.

Data Output and Input

- ePort software to view and change system operation from PC
- Touch screen user interface
- Ethernet with embedded FTP server, USB, RS232, RS485
- 8 User-Defined Analog Outputs (0-1 or 0-5 VDC)
- 2 User-Defined Contact Closure Alarm Circuits
- 4 Averaged Analog Inputs (0-5 VDC) with user-defined conversion to engineering units.

7. MULTICALIBRATOR

Calibration system should provide for the calibration of the ambient air quality monitoring analysers (Gas).

7.1 MULTI POINT GAS CALIBRATION SYSTEM:

1. The Gas Calibration System should be capable to do the following:
 - (i) Multipoint calibration using automatic dilution system for the calibration of SO₂, NO, CO, NH₃ and BTX analyser.
 - (ii) Auto calibration (user selectable).
 - (iii) Generate zero air of 99.9% purity (High Performance Zero Air Generator to be provided).
 - (iv) Gas Phase Titration (GPT) with O₃ generator having 100% converter efficiency for conversion of NO₂ to NO.
 - (v) Calibration using permeation tubes for which at least two chambers based Permeation system has to be provided.
 - (vi) The Permeation System should be capable to accept permeation tubes up to 6 cm in length and 2cm in diameter with user selectable temperature setting of 40 °C and 50 °C.
2. System should be 19" rack mountable.
3. System should be DAS compatible for remote calibration from Central Server.
4. The system should also have facility for multipoint calibration of Ozone analyzer.

7.2 METEOROLOGICAL, FLOW AND ELECTRONICS CALIBRATION

The supplier should provide calibration devices or calibration check devices for ~~all~~ the meteorological parameters namely temperature, wind speed, wind direction, relative humidity, solar radiation, rain fall as per the specifications of the manufacturers.

8. METEOROLOGICAL SYSTEM

8.1 The meteorological instrumentation should be interfaced directly with the Data Acquisition System after passing through a lightning protection isolation box. A crank - up telescopic 10 meters tower should be erected for mounting of meteorological sensors. The relative humidity and solar radiation sensors should be mounted on the tower. The specifications are as follows:

(A) WIND SPEED

Range (Operation)	:	0 – 60 m/s or better
Sustainability	:	Up to 75 m/sec
Accuracy	:	± 0.5 m/sec or better
Resolution	:	0.1 m/sec
Sensor Type	:	Ultrasonic
Threshold	:	0.5 m/sec or less
Response time	:	10 sec or better

(B) WIND DIRECTION

Range	:	0 – 359 degree
Accuracy	:	± 3 degree or better
Resolution	:	1 degree
Sensor type	:	Ultrasonic
Threshold	:	0.5 m/sec or less
Response time	:	10 sec or better

(C) AMBIENT TEMPERATURE

Range	:	-10 ° C to 60 ° C
Accuracy	:	± 0.2 ° C or better (with radiation shield)
Response	:	10 seconds in still air
Resolution	:	0.1 ° C
Sensor type	:	Resistance type
Response time	:	10 sec or better

(D) RELATIVE HUMIDITY

Range	:	0 to 100% RH
Accuracy	:	± 3.0 % or better
Resolution	:	1%
Sensor type	:	Capacitive / Solid State
Response Time	:	10 sec or better

(E) SOLAR RADIATION

Range	:	0 to 1500 W/m ² or better
Accuracy	:	± 5.0 % or better
Resolution	:	5W/m ²
Sensor type	:	Silicon Photo diode

(F) RAINFALL

Range	:	0.2 mm to 100 mm /hr
Accuracy	:	± 5% or better
Resolution	:	0.2 mm
Sensor type	:	Tipping bucket rain gauge or any other suitable sensor
Response Time	:	10 sec or better

(G) TELESCOPIC CRANK – UP METEOROLOGICAL TOWER

The wind speed, wind direction, temperature, relative humidity and solar radiation sensors are to be mounted on the Meteorological Tower. The tower is to be a free standing four section telescopic tower provided with a hand crank to raise and lower the instruments mounted on the tower. Specifications are as follows:

Extended Height	:	10 meters
Retracted Height	:	2 metres
Wind load Limit	:	0.7896 sq. m. (8.5 sq. ft) at 50 mph
Number of Sections	:	4
Construction material	:	Galvanised steel or aluminium

Note: Humidity and temperature sensors are to be supplied with weather and thermal radiation shield made of anodized aluminium and sensor should be supplied with all necessary cables, connector and mounting arrangements as required.

9. DATA ACQUISITION AND COMMUNICATION SYSTEM

9.1 Typical Architecture for Data Connectivity

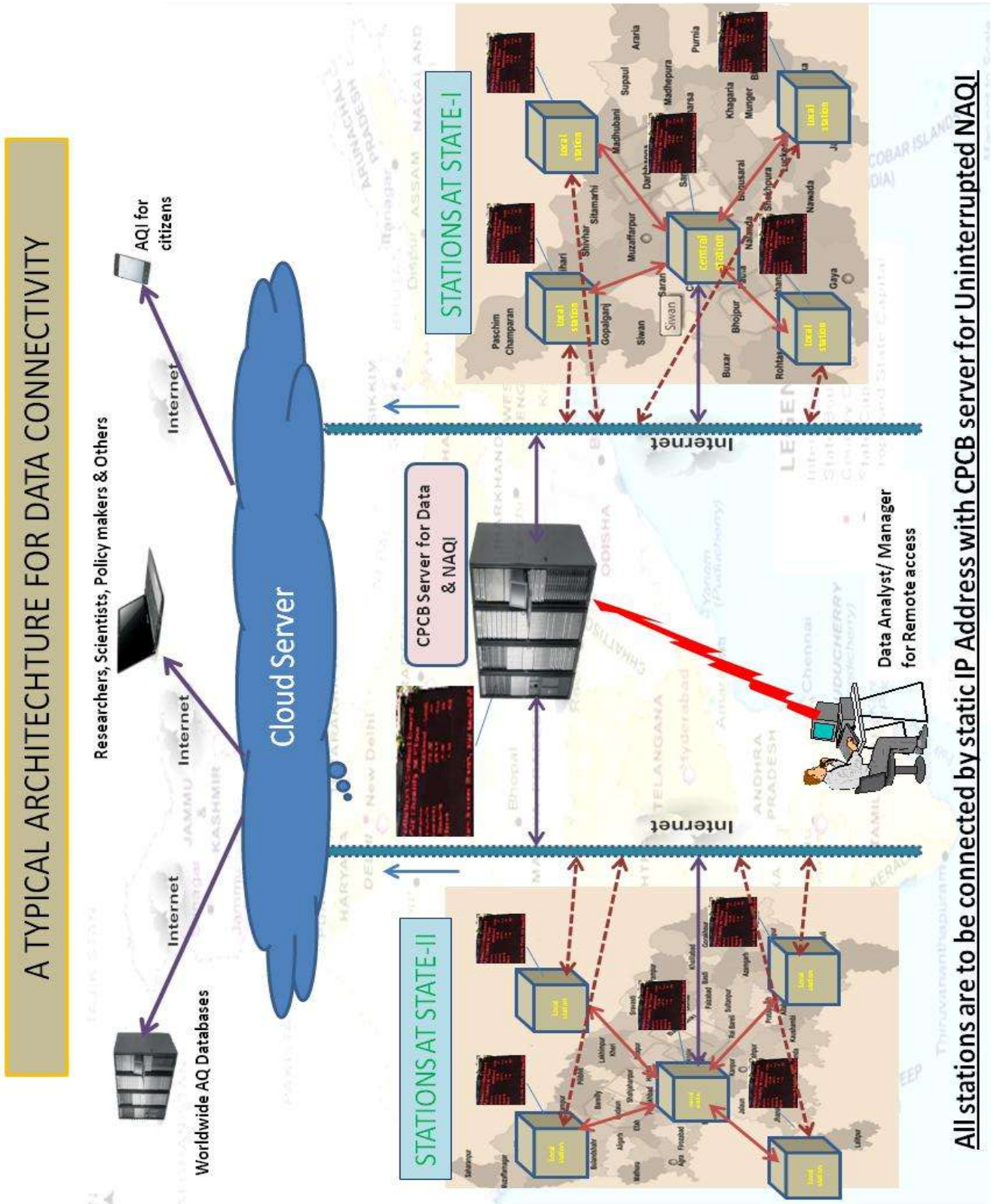

9.2 Data Acquisition and Handling System at Station

Type I: System comprises of data logger having DAS and station computer.

Or

Type 2: System comprises of station computer with DAS facilities.

Data logger/DAS with 8 analog, 24 digital inputs. Ability to log channels at different intervals and should have capability of averaging and displaying real time data and averaged data over a period of 1 min, 15 min, ½ hr, 1 hr, 4 hrs, 8 hrs, 24 hrs, 1 month and year. Communication between data logger and station computer should be using standard USB/RS 232 Connector. The data logger should have internal battery with charger.

The data logger/DAS should support LAN and Internal GSM modem/ Wifi for data transfer to central server. Station computer for data logging will be in addition to workstation computer required for calculating AQI, and will be of same or better specifications that of work station computer.

9.3 WORKSTATION COMPUTER FOR AQI

This has to be installed at CAAQM station for the preparation of AQI along with the station computer.

Sr.No	Specifications	
1	CPU	Intel® Core i7 (3 GHz, 8 MB cache, 4 cores) or higher
2	Memory	8 GB DDR-III, 1066MHz,
3	Ethernet ports	Dual Gigabit Ethernet ports with autosensing bidder can provide 2nd NIC card on PCI , Autosensing is to cater to 100/1000 Mbps speeds automatically and not a boot ROM
4	PCI Slots	Provision for additional cards, 2PCI, PCIex1, PCIx16 (Total 4 slots)
5	Optical Drive	DVD R/W 16X Drive, Internal
6	HDD's	3.5" 1TB, SATA drives
7	Power Supply	Standard suitable power supply
8	Key board	Optical Keyboard same as OEM
9	Mouse	Standard Optical Mouse same as OEM
10	I/O ports	4*USB,
11	Monitor	17" Wide LCD TFT Color Monitor
12	Wireless adapter	USB Wireless adapter x 1 no.
13	OS support	Open source Ubuntu latest release
14	Warranty	Warranty is comprehensive on site including spares for 3 / 3 / 3 years
15	Type	Tower type Black in color preferably or as per the fitting in station rack

9.4 MANAGEABLE CISCO SWITCH (RACK MOUNTABLE) Ethernet switch with LAN and WAN ports.

24 port managed fast/ gigabit Ethernet Cisco Switch with LAN and WAN ports of latest series for installation at respective SPCBs.

9.5 REMOTE MONITORING TOOL/SOFTWARE

Remote management software and its licenses for the entire project duration for station computer and central location at SPCB.

9.6 42 U INDUSTRIAL RACK

This is to be installed at respective SPCBs Central station.

Sr. No	Specifications	QTY / site
1	19" Industrial Rack, 42U , Color Black Consisting of:-	1
2	Steel Enclosure, 9 Folded profile of dimensions 800 mm width * 1000 mm Depth * 42 U height, supporting 1000 Kgs load. Bottom cover with knock out holes for cable entry to be provided. Three pairs of horizontal support shall be fitted on both right and left sides.	1
3	Foldable Front & Rear Door to its half size while opening, shall be of 100% perforated. Provision for mounting fans on Rear door with concealed AC wiring.	2
4	Fan 230V, 90 CFM to be mounted on Rear Door.	4
5	AC Main Channel vertical two nos., 12x 5/15 Amps Sock RT-AQMP Make: Anchor with 32 Amps MCB make : Northwest or better	2
6	Horizontal Cable Manager	20
7	Vertical Cable Manager	10
8	Copper based Electrical Grounding / Earthing Strip. Provision for Fifteen (15) points.	1 Set
9	Each set of: a) Castor with Brake -- 2 Nos.	1 Set
	b) Adjustable screw legs --4 Nos. OR	
	c) Base frame – 1 No.	
10	Light provision activation in the rack up on opening of the front/rear door.	1
11	H/W Packet of 20 SRT-AQMP.	2

If anything else is required to setup the system, vendor need to have provision at the time of quoting.

9.7 RACK SERVER

This is to be installed at respective SPCBs Central station

Sr.No	Specifications	
1.	CPU	Single CPU, Intel Xeon Quad Core E51620V3 3.50 GHz or higher, 10MB Cache per socket or higher. The Mother Board should support Dual Sockets.
2.	Memory	32 (32 GB Support for each CPU) DDR-4, 1333/1600/1866/2133MHz, upgradable to 128 GB
3.	Mother Board	Intel motherboard having compatibility to configuration desired
4.	HDD	3*500GB SAS or better

5.	Ethernet Port	2 *Dual port Gigabit NIC Cards with autosensing and on copper (total 4 ports). All four ports supporting iSCSI protocol to connect to iSCSI based SAN storage
6.	PCI Slots	Provision for 2 *PCI express 2 * PCIe X2 or more slots to accommodate additional FC/Gigabit Cards Graphics Adaptors
7.	Optical Drive	DVD R/W 16X Drive or better, External USB based
8.	Form Factor	2U rack model with rail kit or better
9.	Key board	Standard Optical wireless Keyboard
10.	Mouse	Standard Optical Wireless Mouse
11.	I/O ports	2 *USB ports, front & 2USB port Back, 1 VGA Port, 1 external SAS, 1* Serial
12.	Monitor	22" Wide LCD TFT Colour monitor
13.	RAID Controller	RAID 5 minimum
14.	Wireless adapter	USB Wireless adapter x 2 nos.
15.	Antivirus	Standard Antivirus (McAfee / Norton / Trend Micro) for duration of 3 years
16.	Redundant Power Supply & Fans	Redundant Power Supply 1+1, Redundant Fans
17.	Warranty	Warranty is comprehensive 24x7 on site including spares for 3 / 3 / 3 years with 4 hours support

9.8 ACCESS POINT (AP)

This is required along with server at respective SPCBs central station.

S. No	Specification	
1	Features	1 Ethernet, 1 mini PC Ie, USB, Additional memory, Gigabit, High power, Dual chain, Outdoor case
2	CPU	Atheros AR9342 600MHz network processor
3	Memory	64MB DDR on board memory
4	Ethernet	One Gigabit port with Auto-MDI/X
5	Wireless	Built in 2GHz 802.11b/g/n, 2x RP-SMA connectors
6	Connector type	RP-SMA Female (outside thread)
7	Extras	Beeper, signal and status LEDs, SIM slot (requires 3g miniPCIE card), voltage and temperature sensors

8	Expansion	miniPCIe slot for 802.11 or 3G (using 3G disables the USB port), USB 2.0 port
9	Power options	PoE: 8-30V DC on Ether1 (Non 802.3af). Consumption: 14W at 24V
10	Dimensions	Not more than 400x150x100mm; Weight: 500g
11	OS	of respective OEMs
12	Kit includes	RB912 outdoor unit, PSU, PoE injector, mounting loop, DIN rail mount, mounting ring
13	Frequency Range	2400MHz-2500MHz

9.9 UTM (UNIFIED THREAT MANAGEMENT) DEVICE

This is required at respective SPCBs Central station

Support and Warranty

Appliance should have EAL4+ Certification and ICSA certification for Firewall.

Appliance Throughput

- Firewall throughput of more than 5 Gbps.
- Minimum 1.2 Gbps of Antivirus Throughput
- Minimum 1 million Concurrent sessions
- Minimum 1 Gbps of IPS throughput
- Minimum 45,000 New Sessions/second
- Minimum 800 Mbps of IPsec VPN throughput
- Minimum of 1000 IPsec tunnel support and 50 SSL VPN user support. License for the same should be included in the BOM.
- 810/100/1000 interfaces supporting Hardware Bypass.

General Features

- Should be appliance based and rack mountable
- Identity based Firewall
- Intrusion Prevention System
- Gateway Anti-virus
- Gateway Anti-spam
- Web Content & Application Filtering
- Bandwidth Management
- Inbuilt-on Appliance Reporting
- Network: OSPF, Round Robin load balance, RIPv2, BGP, equal & unequal cost load balance, High Availability, QOS, etc. Round Robin Balance, Server Load Balancing.
- Support for user authentication over SMS.
- Country Based Blocking, FQDN support and should support MIX mode deployment
- 4 Eye Authentication feature for data integrity.

Gateway Antivirus, Anti-Spyware and Anti-Spam

- The proposed Integrated Anti-Virus/Ant-Spyware should have Web coast Checkmark Certification as part of a UTM. Virus, Worm, Trojan Detection and Removal, Automatic Virus signature database update, Real-Time blacklist, MIME header check, Redirect spam mails to dedicated email address, image-spam filter, Spam Notification, Zero hour Virus outbreak protection. Recurrent pattern Detection Technology for AS. Self Service Quarantine area.

Web and Application Filtering:

- The proposed Content Filtering should have at least one Certification as part of a UTM viz. Web coast Checkmark. URL, Keyword, File type block, Block Java applets, cookies, ActiveX, Block malware, phishing, pharming URL, block P2P application, anonymous proxies, Customized block on group basis. System should have Minimum of 70+ categories with more than 100 million URLs supported with more than 5000 application support.

Security Features

- **Intrusion Prevention System (IPS):** The proposed IPS should have Certification as part of a UTM viz. Web coast Checkmark. For different attacks like Mail Attack, FTP Attack, HTTP Attack, DNS Attack, ICMP Attack, TCP/IP Attack, DOS and DDOS Attack, Tel Net Attack. Signatures: Default (more than 2000+), Custom , IPS Policies: Multiple, Custom, User-based policy creation, Automatic real-time updates from CR Protect networks, Protocol Anomaly Detection
- **VPN:**

IPsec, L2TP, PPTP and SSL as a part of Basic Appliance, VPN redundancy, Hub and Spoke support, 3DES, DES, AES, MD5,SHA1 Hash algorithms, IPsec NAT Transversal, VPNC Certified.
- **Load Balance:**
For Automated Failover/Failback, Multi-WAN failover, WRR based Load Balancing. High availability: Active-Active. QOS, OSPF, RIPv2, BGP, Policy routing based on Application and User support Round Robin Load Balancing.
- **Bandwidth Management:**
Application and user identity based bandwidth management, Multi WAN bandwidth reporting, Guaranteed and Burstable bandwidth policy. Bandwidth for User, Group, Firewall Rule, URL and Applications.
- **Monitoring and Reporting System:**
Should Include reports for Centralized management, Monitoring & Logging, Command line interface. Monitoring Gateways, **Monitoring suspicious activity and alerts**, Graphical real-time and historical monitoring, email notification of reports, viruses and attacks reports. IPS, Web filter, Antivirus, Anti-spam system reports. IP and User basis report, >40+ Compliance reports and >1000+ drilled down reports on the appliance with 250+ GB of storage.

License for UTM (Unified Threat Management)

Three Years for Gate Way Antivirus, spyware, Anti-Spam, content and application filtering. IPS, reporting and support License period will be counted after activation

9.10 CONNECTIVITY FOR DATA TRANSFER

A) LEASED LINE CIRCUIT

1Mbps capacity leased line connectivity with 99% uptime service level agreement (SLA) to be provided by the firm at each station location. The leased line may be provided on copper or optical fiber or through RF depending upon the location.

B) BROADBAND

1Mbps capacity broadband connectivity from other than one already providing leased line connectivity shall be provided by the firm at each station.

C) GSM /Hotspot Connectivity

Internet connectivity will have to be provided by the firm for the entire project duration at LED location either using GSM or Hotspot connectivity

10. DATA ACQUISITION SOFTWARE FOR STATION (CAAQM)

The software captures data from all channels in the system and stores in the station Computer.

(i) Data Acquisition

- a) Frequency of data acquisition
 - i) User selectable 1,5,30,60,120 second averaging duration online digitally.
- b) Channel size
 - i) 32 Channels or more supported
 - ii) Expandable to 64 channels, if required in future
- c) Data input
Either Analog (0-1 volt/0-10 volt/2-20mA/4-20mA)
or Digital to configure with the PC.
- d) User configurable channels, stations and equipment with communication parameters.
- e) Analyzer data channel should comprise of Name, Units, Communication Address, Validity Range, Operation and Error Status.
- f) Provision to incorporate conversion factors such as PPB to $\mu\text{g}/\text{m}^3$ etc.
- g) Software should be equipped to configure the analyzers with it, irrespective of company make and communication protocol of the analyzer and the output mode i.e. Analog or Digital (RS 232) of the instrument.
- h) The output should be provided in user defined units.

(ii) Data Collection

- a) Average data over user selectable time (1,5,30,60 seconds time interval) period.
- b) Operational status, Error status, calibration status and calibration values observed from the analyzer should be captured and should be made available along with the data with a frequency of maximum five minutes.
- c) System should collect of the diagnostics of the instrument comprising actual diagnostics parameters and their values at least once in every five minute to check the state of the health analyzer.
- d) Calibration parameters
 - i) Provision to entering zero calibration, span calibration values of gas cylinder/permeation to devices
 - ii) Provision for collecting zero calibration, span calibration values(pre calibration & post calibration) in to the database for further analysis.
 - iii) Provisions to collect electronic system pre calibration & post calibration to ascertain the percentage deviation/ correction apply during each calibration.

(iii) Data Storage

- a) Data along-with diagnostic, calibration, alarms should be stored at station computer at a defined path.
- b) Interval of data dumping will be same as defined in the data collection.
- c) System should be capable to keep every second acquired data from 32 channels for a period of minimum five years.
- d) Current data should be stored as per ISO-7168-1:1999I format and should be available in folder named as c:\Data\ at an interval of 15 minutes. As an example c:\data\01.05.2015.xml. the file will be appending without double data entry and as per ISO format.
- e) Data should also be stored for last two years in E:\data\Year\Month\day i.e. e:\data\2015\05\01.05.2015.xml
- f) If data encryption is done, then decryption procedure should be made available in soft file format to check the data at station at any point of time.

To convert data on continuous basis for exporting to AQI software, procedure should be available without any licensing. AQI calculating Software will be provided by CPCB/SPCB.

(iv) Data Display (Statistical analysis of data)

- a) Main window for real time display of all measured parameters with status of all analyzers/sensors.
- b) In 4-in-4 graphs and 4-in-1 graph formats
- c) In tables of 4-in-1 format
- d) Real time multi – graphs over user selectable time period i.e. 6.00 AM to 6.00 AM etc.
- e) Display of graphic & tabular display of the current data.
- f) Graphical form should comprise of 4-4 graphs, 4-1 graphs in user defined format (1, 5, 10, 15, 30 min, 1hour, 4, 8, 24 hour, 30 days and yearly; user definable time series)
- g) Tabular form should comprise of 4 channel list in user defined format (1, 5, 10, 15, 30 min, 1hour, 4, 8, 24 hour, 30 days and yearly; user definable time series)
- h) Station instruments basic configuration etc. should be visible on screen continuously.
- i) Statistical analysis tools like regression analysis, co-relation analysis and other analysis as per industry standards in the field of environment should be available and if not the firm should develop these for CPCB within a time frame of six months.
- j) The system should have procedures for normal analysis tools like calculation of data with respect to a threshold value, average, minimum, maximum, calculation of violating value with respect defined values(National Air Quality Standards) for defined period for the database etc.
- k) Data analysis of diagnostics parameters
- l) Data analysis of Pre calibration and post calibration data (if facility not available, should be developed within six months)
- m) Data analysis of corrections applied of each calibration cycle (if facility not available should be developed within six months)

(v) Data Backup

- a) There should be defined data backup procedure through which data can be extracted from station computer in simple text format/excel/ ISO format(user definable).
- b) There should be defined restore procedure also to restore the data in case of data loss.
- c) A display screen should be available to update the user about data availability.

(vi) Data Validation automatic checks at station software.

- a) Zero level and span level checks if performed cyclically and defined results are not obtained up to +/- 5%(user definable 0-10%) then system should alarm the user of system failure and the recorded alarm should be transmitted to central software.
- b) After instruments perform the calibration the results obtained should be recorded and should be transmitted to central computer.
- c) There should be provision of two databases one is raw database and another corrected database.
- d) Validation of data through calibration database Pre calibration & post calibration values collected.

(vii) Calibration of systems

- a. Calibration window for analyzer for the calibration from computer.
- b. Remote Access to Calibration: Calibration exercise need to be done remotely. All necessary arrangements for it should be made in the system.

- c. Calibration data file may be prepared separately and data should be excluded from the database
- d. Calibration database need to be formed, stored and transmitted to central server.
- e. Calibration cycles to be as per the models of the instruments.
- f. Calibration records should store the calibration values displayed by instrument.
- g. Diagnostics during calibration should also be recorded.

(viii) Location of station

- a) Fixed and Mobile Stations location to be recorded and North correction feature should be available.
- b) Latitude and longitude of stations be recorded

(ix) Data transfer to Central

All data captured at station computer should be transferred to central software.

- a) User selectable time frame for transmission of data to central server.
- b) Diagnostics (actual diagnostics parameter values recorded each time in the station), configurations(station channel configurations), alarms(generated alarms) should be transmitted.

(x) Data transfer to Display Boards at Public site

software should have provisions to connect data output including current pollutants concentration, AQI, advertisement, etc. to the display boards (LEDs), to be installed at public site. For the purpose Data display device has been recommended in the document.

11. DATA ACQUISITION SOFTWARE AT THE CENTRAL STATION AT SPCB

Data communication system handles the data transmission of an ambient air quality network and receives incoming messages / signals from remote stations. The central software processes signals and data and displays it. Detailed requirement is as below:

A (i) Software at Central Station

- a) Software should not have any restriction on number of locations and computers either technologically or in terms of licensing.
- b) Should display multiple stations on – line data (momentary values) in tabular text and graphic format.
- c) Data should be received by the central from all locations maximally within 5minutes duration or at user defined time intervals.
- d) Data along-with diagnostics and calibration details should be transmitted at central from all connected locations.
- e) Should support dialup systems, broadband connectivity, wireless connectivity, 2G or 3G or any new technology which shall be in place during project time should be compatible and if not, need to developed by the system provider up-to project duration without additional charges.
- f) Should have the remote control facilities for calibrations (Zero & Span) of instruments and measuring range modifications.
- g) Should have facility for displaying data communication error reports, image management which should be recorded and should be available for display.

(ii) Data Display at Central Station

- a) In 4-in-4 graphs, 4-in-1 graph and/or 16-in-1 graph formats
- b) In terms of 4-in-1 table format
- a) Real time multi – graphs over user selectable time period i.e. 6.00 AM to 6.00 AM etc.

- c) Display of graphic & tabular display of the current data like simple 3D line and column chart, polar diagnostics and 3D perspective column chart.
- d) Graphical form should comprise of 4-4 graphs, 4-1 graphs in user defined format i.e. 1, 5, 10, 15, 30 min, 1hour, 4, 8, 24 hour, 30 days and yearly. (user definable time series)
- e) Tabular form should comprise of 4 channel list in user defined format i.e. 1, 5, 10, 15, 30 min, 1hour, 4, 8, 24 hour, 30 days and yearly. (user definable time series)
- f) Display of data using selectable name of different stations.
- g) Generation of Wind Roses, Pollution Roses (minimum 12 directional)with user defined time limits.
- h) Calculate vector mean of wind direction.
- i) Programmable downloading of data.
- j) Comparison of data w.r.t. Standards in Graphical form and tabular form with information of values exceeds the Standards.
- k) Specific data zooming facility
- l) Database correction procedure
- m) Separate user ID and Password for correction of database so that all regional level users if authorized can validate their regions data and the events be recorded along-with ID and time.
- n) Data validation trail recording.

(iii) Data Export

- a) Data export in ISO 7168 format is required to be done automatically.
- b) Possibility to export the data files in Excel, Text and other formats Tabular form should be in user defined format i.e. 1, 5, 10, 15, 30 min, 1 hour, 4, 8, 24 hour, 30 days and yearly.

(iv) Data Import

- a) In case of communication medium fails there should a mechanism to shift the data into Pen drive (Physical medium for data collection) physically and a procedure to import the same on central software.

(v) Printing

- a) Possibility to connect different types of printers and auto printing facility for all displays generated throughout the analysis of data at any point of time.

(vi) Delayed data checks at Central software at SPCB

- a) After instruments perform the calibration the results obtained should be recorded and should be transmitted to central computer and stored.
- b) Zero level and span level checks if performed cyclically and defined results are not obtained up to +/- 5% (user definable 0-10%) then system should generate alarm to the user for system failure and the recorded alarm should be transmitted to central software and stored. There should be provisions to read these alarms in a database for corrective actions and for comparison of data for acceptability or rejection.
- c) Procedure to correct database through correct ISO 7168 file should be generated at SPCB and it should be synced with Software under development at Central Pollution Control Board (CPCB).

(vii) Data display at SPCB Office / specific location through central software

The software should have capability to display set of data including AQI etc. for all the monitoring locations and cities (user selectable) in the State through slide show mechanism.

(viii) Remote Procedures (if not available facility should be developed by the firm)

- a) Central software should have capability to allow to connect any station computer through remote.
- b) Central software administrator should be able to go for remote calibration of any of the systems.
- c) Software should be capable to operate remote stations configurations.
- d) Control panel window should be available for controlling each analyzer.
- e) Alarm window for valid alarms of all analyzers and sensors.
- f) It should have transparent data – connection to each analyzer from remote.
- g) System should be capable to remotely configure all stations through remote location using configuration file to maintain the uniformity. The configuration command from central at SPCB location should be active.

(ix) Data Reports Generation

- a) To prepare reports hourly, weekly, monthly, yearly in user defined interval and formats.
- b) Mean, Median, Percentile, Maximum, Standard deviation, Frequency analysis and Maximum Frequency analysis.
- c) Data Comparison
Software should be able to compare any of the four channels irrespective of type of data in the system with respect to each other on a single time scale user selectable.
- d) Data Comparison on different time scale
Software should be able to compare data on the basis of different time scales like one station (x) parameter (y) of one given date is compared with other station (z) parameter (y) on any other date in a single graph.
- e) Data reports, calibration reports and status reports with user time periods.
- f) Historic multi – curves / graphs over user selectable time period.
- g) Report generation over user selectable time period (instantaneous or averaged over a period of 1, 15, 30 min, 1 hr, 4, 8, 12, 16 and 24 hrs etc.).
- h) Diurnal variation, standard deviation, regression and other statistical parameter reporting possibilities with various available mathematical methods.
- i) If required separate report generation procedures have to be developed for which firm will be responsible for project duration.
- j) Data should be downloadable in Excel Sheet, CSV format through user selection.

B. SECURITY

- a. Software should be totally secured with protection against virus, malware etc.
- b. Security device like firewall for VPN Tunneling should be installed.

C. OTHER TECHNICAL CONDITIONS

1. Compatible Hardware required for data transmission through Data Display Connection Device has to be installed.
2. Should support the latest formats of Windows 32 bit or 64 bit. Any new patches developed or upgraded software during project duration should be provided without additional cost.
3. Manual of complete system should be provided.
4. Firm should provide the hardware required for data acquisition along with all the software's required like OS, Networking software, Remote functionality software and should maintain hardware and software for project duration.

12. DISPLAY BOARD DATA TRANSMISSION DEVICE

S. No.	Item Desc.	Specifications
1.	PROCESSOR	Intel® Atom™ Processor E3815 (1.46 GHz Single Core, 512 KB Cache, 5W TDP) or equivalent Or 900 MHz or higher quad-core ARM Cortex-A7
2.	Memory	Memory slots for MicroSD or full size SD card slot with Memory support for at-least 8 GB
3.	Ports	<ol style="list-style-type: none"> a. One HDMI b. LAN Port for Ethernet Network Connection c. Minimum of 3 USB Port with support for USB 2.0 or USB 3.0.
4.	OS Support	Linux, or Windows OS
5.	Communication Options	<ol style="list-style-type: none"> a. LAN Communication b. Wifi Communication – Wifi Hotspot enabled/ GPRS Comm. Enabled
6.	Power Supply	5 to 12 V DC through 220 V 50Hz AC Supply adapter or USB driven.
7.	Size	Mechanical Chassis Size not to exceed 9" x 6"x 6" with stand alone tower/box.
8.	Operating Environment	Operating Temperature 0° C to +50° C Humidity upto 90%
9.	Device Support	05 Years
10.	Antivirus	It should be secured If Windows than life time antivirus should be there.
11.	General	Supplier will configure and deploy the communication mechanism. Complete manual of the device should be provided.
12.	Accessories	01 Meter HDMI Cable
13.	Internet	To be provided by the vendor either through GSM SIM or through Wifi Enabled Dongles.
14.	Display Board should show	Last data saved.
15.	Display board should show	Last updated time should be displayed
16.	Software	The vendor is responsible to provide software which can download the data from Station computer, AQI, Advertisements etc. store it and display on the Display Board seamlessly.

13. DAY LIGHT & NIGHT VISIBLE DATA DISPLAY SYSTEM

(A) LOCATION NEAR TO CAAQM STATION

1.	Size of Display System (H X W) feet and Pixel	4 X 7 feet , 16 mm (+/- 0.5 mm) pixel pitch, 3500 m ² minimum pixel Density
2.	Visibility Range	50 Meters (Day time)
3.	Brightness	8500 NIT or higher
4.	Display of Colour Elements	1Red , 1Green, 1Blue pixel
5.	Minimum Life span of the system	LED Life 100000 Hours
6.	Viewing angle	Viewing angle of 140° Horizontal/77° Vertical
7.	Operating and non operating Temperature	-15-55° C
8.	No of Color	281 trillion Colors , 256 brightness level dimming capability
9.	Video processing	24 bit Video processing, 100 % Digital
10.	Diode Density	1100m ² / 1000 ft ² (minimum)
11.	Scan rate and refresh frequency	Scan Ratio 1:1 and with minimum 20000 hz refresh frequency
12.	LED internal and External Cabinet type , Serviceability	Internal LED frame should be made of Aluminium and External cabinet should be factory made without pin holes , LED Display should be serviceable from front and back
13.	Color Temperature - Adjustable	4500 - 9000 K range
14.	Input Power Requirement/ Consumption	120/240v, 50/60Hz , Power consumption 200 W (maximum) / m ²
15.	Type	Discrete Diode
16.	Display Mounting	Structure based upon location. Uni Pole or hanging
17.	General	The system should also have the facility to display the enviromental picture through video camera/vcr/cd player etc. for public awareness.
18.	Power Cable Laying	Depending upon location, cabeling is to be done by the firm
19.	Device at station to pick up data and transmit it to LED	Display data connectivity device with GSM SIM has to be installed near by LED board which will pick up data from station computer through Internet. LED to be placed away from through Internet .LED to be placed away from the station premises.
20.	Certification	CE, UL/ULC listed
21.	IP Rating	Display Module IP67, Cabinet IP 65

(B) DAY LIGHT & NIGHT VISIBLE DATA DISPLAY SYSTEM**LOCATION FAR AWAY FROM CENTRAL STATION OF STATE
POLLUTION CONTROL BOARD (SPCB)**

1.	Size of Display System (H X W) feet and Pixel	8 X 12 feet , 20 mm (+/- 0.6 mm) pixel pitch, 2300 m ² minimum pixel Density
2.	Visibility Range	50 Meters (Day time)
3.	Brightness	8500 NIT or higher
4.	Display of Colour Elements	1Red , 1Green, 1Blue pixel
5.	Minimum Life span of the system	LED Life 100000 Hours
6.	Viewing angle	Viewing angle of 140° Horizontal/59° Vertical
7.	Operating and non operating Temperature	-.15-55 ⁰ C
8.	No of Color	281 trillion Colors , 256 brightness level dimming capability
9.	Video processing	24 bit Video processing, 100 % Digital
10.	Diode Density	7000m2 (minimum)
11.	Scan rate and refresh frequency	Scan Ratio 1:1 and with minimum 20000 hz refresh frequency
12.	LED internal and External Cabinet type , Serviceability	Internal LED frame should be made of Aluminium and External cabinet should be factory made without pin holes , LED Display should be serviceable from front and back
13.	Color Temperature - Adjustable	4500 - 9000 K range
14.	input Power Requirement/ Consumption	120/240v, 50/60Hz , Power consumption 180 W (maximum) / m ²
15.	Type	Discrete Diode
16.	Display Mounting	Structure based upon location . Uni Pole or hanging
17.	General	The system should also have the facility to display the environmental picture through video camera/vcr/cd player etc. for public awareness.
18.	Power Cable Laying	Depending upon location, cabling is to be done by the firm
19.	Device at station to pick up data and transmit it to LED	Display data connectivity device with GSM SIM has to be installed near by LED board which will pick up data from station computer through Internet. LED to be placed away from through Internet .LED to be placed away from the station premises.
20.	Certification	CE, UL/ULC listed
21.	IP Rating	Display Module IP67, Cabinet IP 65

14. ANNEXURE

(A) Drawing of a CAAQM Station

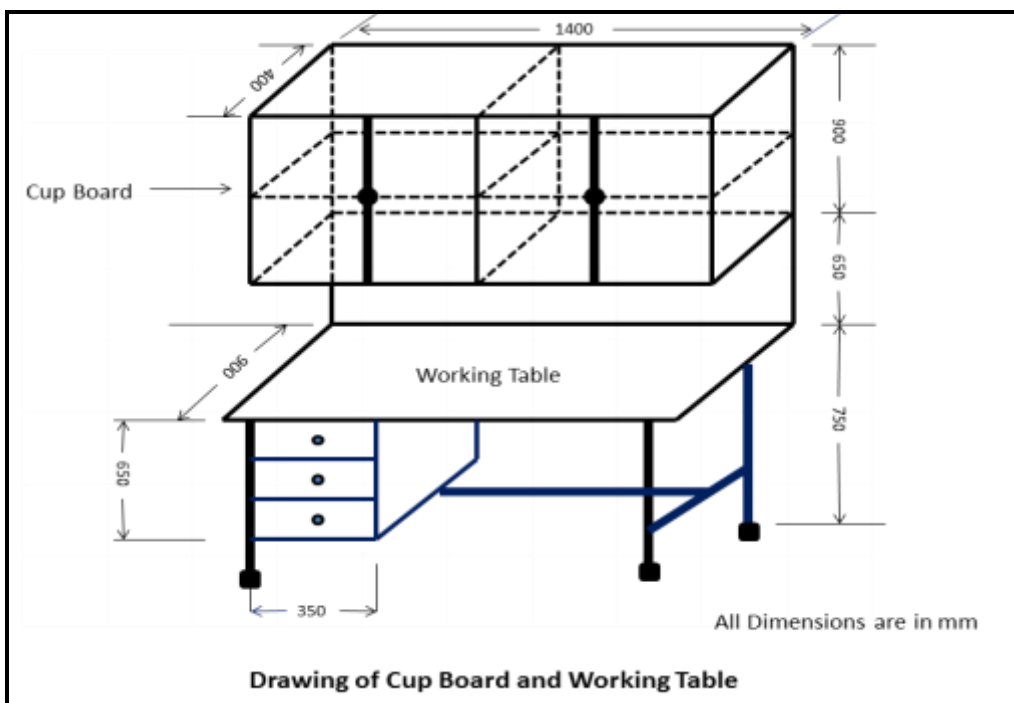
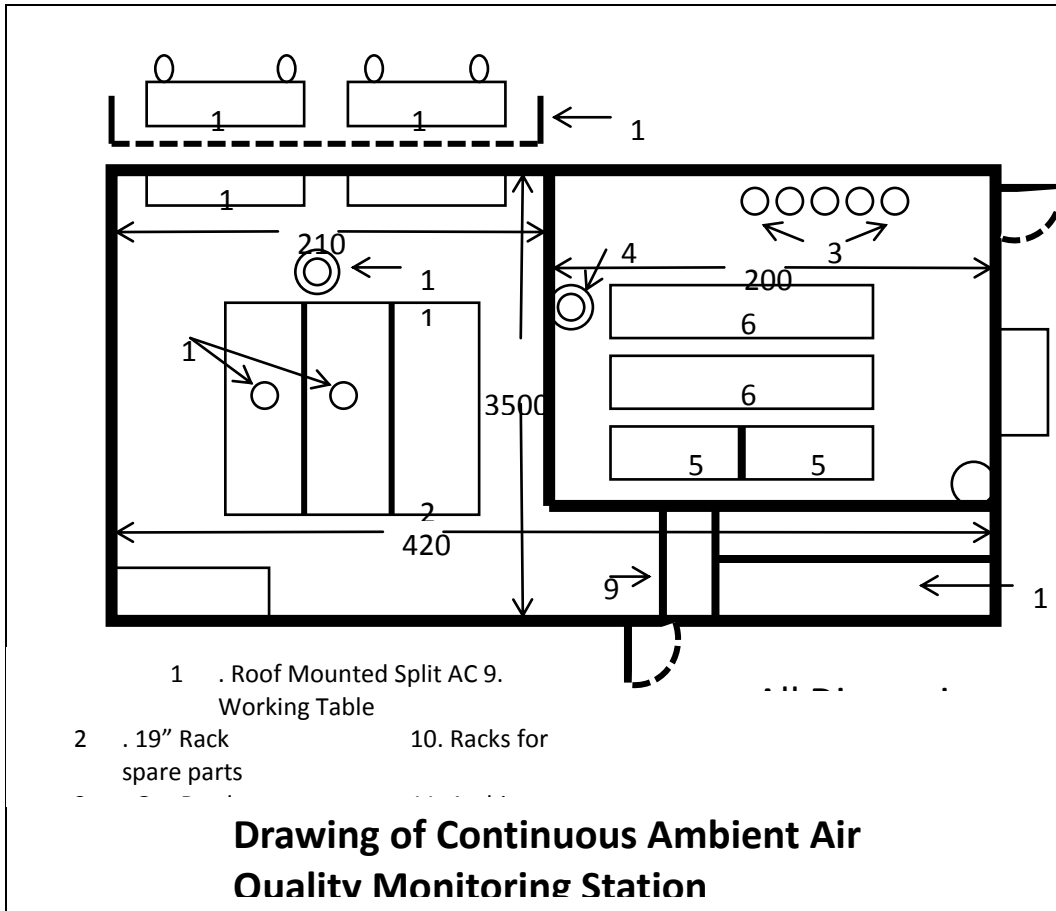

(B) Architecture of CAAQM System

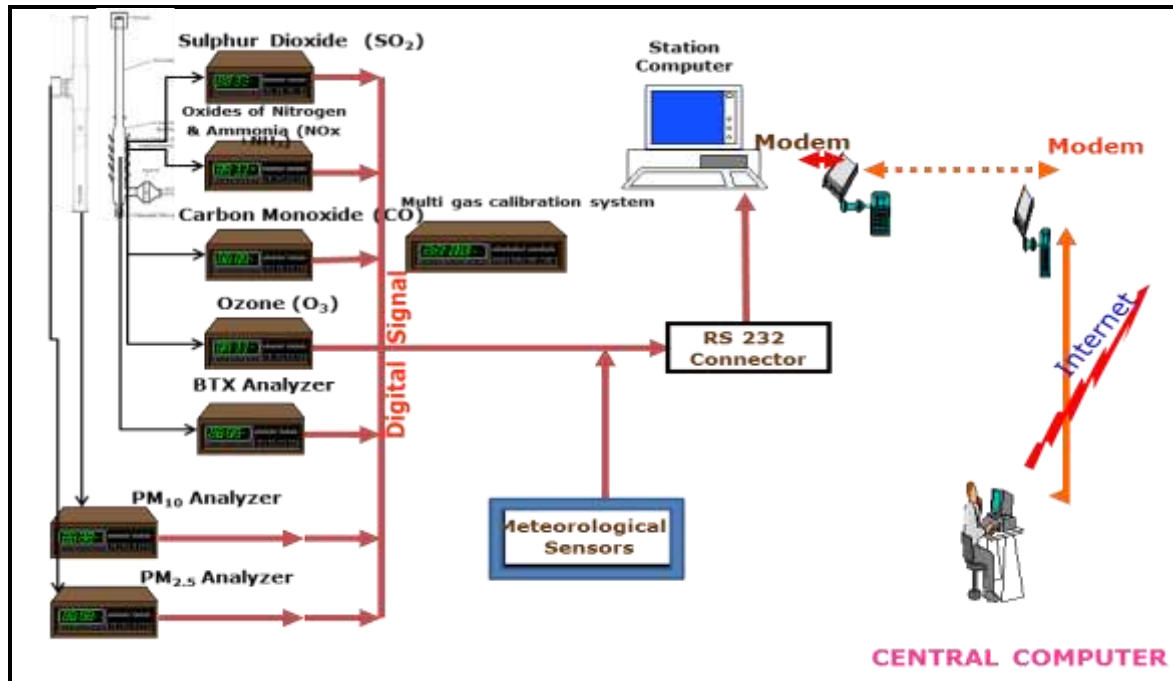

(C) Protocol for Data Transmission from CAAQM Stations

1. Data Format

- Data file on real time basis having 15 minutes average values in a prescribed format attached at Annexure-I should be generated at the station for which Instrument Supplier is responsible.
- File should be updated after every 15 minutes.
- Data intervals like 00:15, 00:30, 00:45, 01:00 should be fixed at the station.
- Station file name should be exactly as the name of the station to be displayed on the web portal. i.e. Sanathnagar, NehruNagar. Here precaution is to be taken that no space between words should be given or no special characters should be used.
- File should be recorded in a folder c: \data \sanathnagardata.txt
- File should allow data appending sequentially.
- Date of last file record appended in the file should be recorded and data afterwards be placed in the data file.
- File appending should continue subject to max 97 lines. First in First out mechanism shall be followed in keeping file size to 97 lines.

- Hence, in the specified folder c:\Data\ there will be a single file which will keep appending as per format attached.
- Duplicate entry of any data should not be made in the file.
- System should have capability to create previous record data file for which user will give the date. This is required to have lost data makeup in the final database, if any.

2. Data Mapping

- Protocol for each parameter is fixed as below:
 1. 15 Minutes average value will be provided by the operator of the CAAQMS
 2. Each SPCB will have the parameter as mentioned in the table only. Not even a small gap or space is provided other than the mentioned table is acceptable.

3. Standard Parameter Naming Protocol and Conversion factors Table

Parameters Name	Parameter Abbreviations	Unit	Conversion factors at 25°C
Rack Temperature	Temp	°C	
Carbon Monoxide	CO	mg/m ³	1ppm=1.145mg/m ³
Sulphur Dioxide	SO ₂	µg /m ³	1ppb=2.62 µg/m ³
Nitric Oxide	NO	µg /m ³	1ppb=1.23 µg/m ³
Nitrogen dioxide	NO ₂	µg /m ³	1ppb=1.88 µg/m ³
Oxides of Nitrogen	NO _x	Ppb	--
Ozone	Ozone	µg /m ³	1ppb=1.96 µg/m ³
Particulate Matter less than 10 Micron size	PM ₁₀	µg /m ³	--
Wind Speed	WS	m/s	--
Wind Direction	WD	Deg	--
Ambient Temperature	AT	°C	--
Relative Humidity	RH	%	--
Barometric Pressure	BP	mmHg	--
Solar Radiation	SR	W/mt ²	--
Rain Fall	RF	Mm	--
Vertical Wind Speed	VWS	Degree	--
Particulate Matter less than 2.5 micron size	PM _{2.5}	µg /m ³	--
Benzene	Benzene	µg /m ³	1ppb=3.19 µg/m ³
Toluene	Toluene	µg /m ³	1ppb=3.77 µg/m ³
Xylene	Xylene	µg /m ³	1ppb=4.34 µg/m ³
Ethyl Benzene	Eth-Benzene		1ppb=4.34 µg/m ³
M+P_Xylene	MP-Xylene		1ppb=4.34 µg/m ³
Methane	CH ₄	µg /m ³	1ppb=0.65 µg/m ³
Ammonia	NH ₃	µg /m ³	1ppb=0.70 µg/m ³
Formaldehyde	HCHO	µg /m ³	1ppb=1.23 µg/m ³
Mercury	Hg	µg/m ³	1ppb=8.20 µg/m ³

Note: 1. Any other parameter can be added with the prior approval of IT Division ONLY.

4. Internet Connectivity

- Internet connectivity should be available on 24X7 basis for data transmission with an uptime of 99.9%. For this purpose every CAAQM station should have two kinds of connection:
 - i) Leased Line Circuit of at least 01 Mbps capacity
 - ii) Broad Band connectivity through telephone line. Both facilities should be configured in ready to use condition. If possible auto failover should be created.

Note: Connectivity through Data card is not acceptable except in any special circumstances, where both of these types of connectivity's are not available. For such case CPCB IT Division shall be consulted before taking a final decision.

5. Other Information:

1. Area Map showing station location
2. Latitude, Longitude and altitude of the station
3. Photo of station along with nearby areas
4. One page write-up about the station activities in the vicinity of station including major pollution sources like nearby road, rail, restaurants, generator sets, etc.

Annexure – I

File Name: sanathnagar

1,2,3,4,5,6,7,8,

Station name, Parameter, Date from, Date to, Value, calibrationflag, maint flag, Remark,

Sanathnagar,CO,27-04-2015 13:00,27-04-2015 13:15,0.2497,0,0,analyserfaulty,
Sanathnagar,C0,27-04-2015 13:15,27-04-2015 13:30,0.2470,0,0,analyserfaulty,
Sanathnagar,C0,27-04-2015 13:30,27-04-2015 13:45,0.2470,0,0,analyserfaulty,
Sanathnagar,C0,27-04-2015 13:45,27-04-2015 14:00,0.2470,0,0,analyserfaulty,
Sanathnagar,Ozone,27-04-2015 13:00,27-04-2015 13:15,59.6710,0,0,flowproblem,
Sanathnagar,Ozone,27-04-2015 13:15,27-04-2015 13:30,59.5960,0,0,analyserfaulty,
Sanathnagar,Ozone,27-04-2015 13:30,27-04-2015 13:45,59.5960,0,0,analyserfaulty,
Sanathnagar,Ozone,27-04-2015 13:45,27-04-2015 14:00,59.5960,0,0,analyserfaulty,
Sanathnagar,N0,27-04-2015 13:00,27-04-2015 13:15,0.5922,0,0,analyserfaulty,
Sanathnagar,N0,27-04-2015 13:15,27-04-2015 13:30,0.4435,0,0,0,
Sanathnagar,N0,27-04-2015 13:30,27-04-2015 13:45,0.4435,0,0,0,
Sanathnagar,N0,27-04-2015 13:45,27-04-2015 14:00,0.4435,0,0,0,
Sanathnagar,So2,27-04-2015 13:00,27-04-2015 13:15,3.5233,0,0,0,
Sanathnagar,So2,27-04-2015 13:15,27-04-2015 13:30,3.7278,0,0,0,
Sanathnagar,So2,27-04-2015 13:30,27-04-2015 13:45,3.5233,0,0,0,
Sanathnagar,So2,27-04-2015 13:45,27-04-2015 14:00,3.7278,0,0,0,
Sanathnagar,RT,27-04-2015 13:15,27-04-2015 13:30,33.2260,0,0,0,
Sanathnagar,RT,27-04-2015 13:30,27-04-2015 13:45,33.2240,0,0,0,
Sanathnagar,AT,27-04-2015 13:45,27-04-2015 14:00,33.0960,0,0,0,
Sanathnagar,AT,27-04-2015 14:15,27-04-2015 14:30,33.3740,0,0,0,
Sanathnagar,RH,27-04-2015 13:15,27-04-2015 13:30,41.3080,0,0,0,
Sanathnagar,PM10,27-04-2015 13:15,27-04-2015 13:30,30.3000,0,1,analyserfaulty,
Sanathnagar,PM10,27-04-2015 13:30,27-04-2015 13:45,30.3000,1,0,analyserfaulty,

Please note:

Here 0-zero stand for normal operation of instruments in **calibration flag status**

1-Stands for calibration mode ON and data will not be considered for averaging purpose.

Same is true for Maintenance mode where 0-normal and 1 maintenance mode ON